

Twin Rod Cylinder

Double Acting, Single Rod / Double Rod

Series CXS, CXSW

◆ How to Order

CXS W M 20-100

Standard stroke

* Refer to "Standard stroke" .

Bore size (mm)

6	10	15	20	25	32
---	----	----	----	----	----

Bearing type

M	Slide bearing
L	Ball bushing bearing

Piston Rod

Nil	Single rod
W	Double rod

Model

CXS	Twin rod cylinder, built-in magnet, double acting; single rod
CXSW	Twin rod cylinder, built-in magnet, double acting; double rod



Symbol

CXSM□-□

CXSWM□-□



◆ Specifications

Bore size (mm)		6	10	15	20	25	32
Action	CXSM□-□	Double acting, single rod					
	CXSWM□-□	Double acting, double rod					
Fluid		Filtered compressed air					
Proof pressure		1.05 MPa					
Operating pressure range	CXSM□-□	0.15~0.7 MPa	0.1~0.7 MPa			0.05 ~0.7MPa	
	CXSWM□-□	0.15~0.7 MPa				0.1 ~0.7MPa	
Ambient and fluid temperature		-10~60℃ (No freezing)					
Port size		M5×0.8				Rc1/8	
Cushion		Rubber bumper					
Stroke adjustable range	CXSM□-□	0 to -5mm compared to the standard stroke.					
	CXSWM□-□	0 to -10mm compared to the standard stroke. (extended end: 5mm, retracted end: 5mm)					
Bearing type		Slide bearing / ball bushing bearing (same dimensions for both)					

◆ Standard Stroke

Bore size(mm)	CXS(double acting, single rod)		CXSW(double acting, double rod)	
	Standard stroke(mm)	Manufacturable stroke range	Standard stroke(mm)	Manufacturable stroke range
6	10, 15, 20, 25, 30, 35, 40, 45, 50,	60 to 100	10, 20, 30, 40, 50	-
10	10, 15, 20, 25, 30, 35, 40, 45, 50, 60, 70, 75	80 to 150	10, 20, 30, 40, 50	75, 100, 125, 150
15		110 to 150		
20	10, 15, 20, 25, 30, 35, 40, 45, 50, 60,	110 to 200	10, 20, 30, 40, 50, 75, 100	125, 150, 175, 200
25	70, 75, 80, 90, 100			
32				

Twin Rod Cylinder

Double Acting, Single Rod / Double Rod

Series CXS, CXSW

ANSSION
PNEUMATIC & HYDRAULIC

◆ **Dimensions**

CXSM□-□ Φ6
CXSL□-□ Φ6

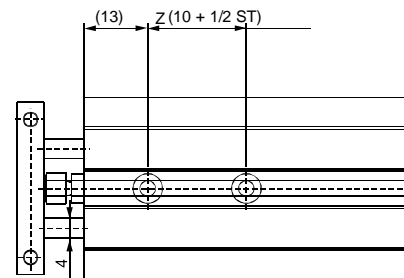
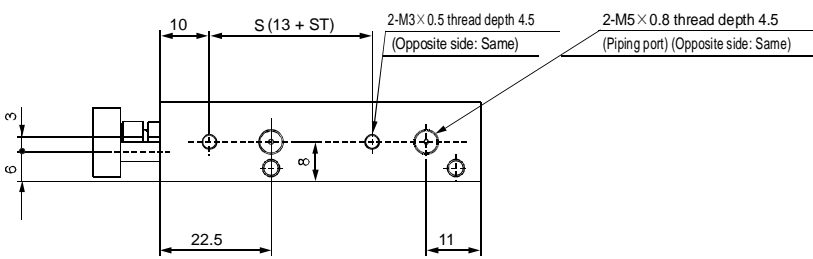
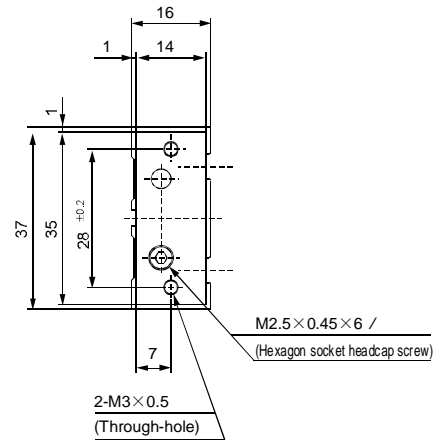
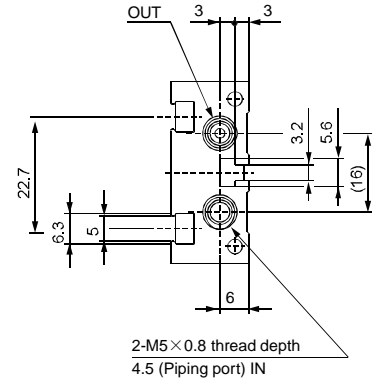
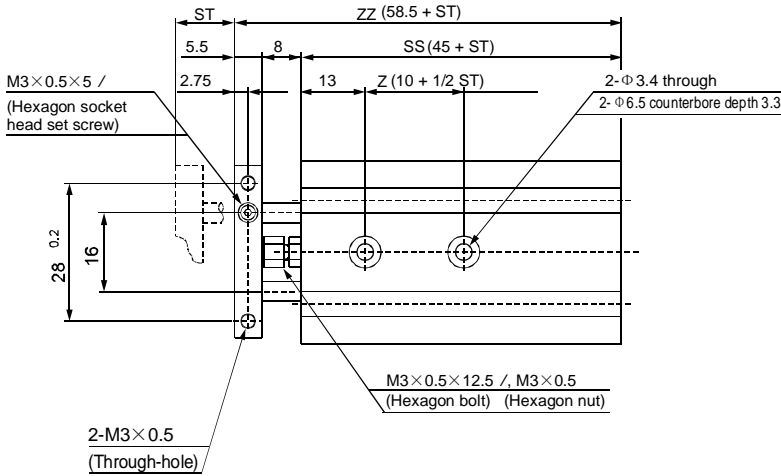

Note): Slide bearing (M) and ball bushing bearing (L) are same dimensions.

Model	Stroke	Z	S	SS	ZZ
CXS □ 6-10	10	15	23	55	68.5
CXS □ 6-20	20	20	33	65	78.5
CXS □ 6-30	30	25	43	75	88.5
CXS □ 6-40	40	30	53	85	98.5
CXS □ 6-50	50	35	63	95	108.5

I

CJP

CJ1

DNC

DNCB

DNG

C95

SI

CS1

MB

SU

SC

DSNU

C85

CJ2

CM2

MA

MAL

ADVU

CQ2

CQS

SDA

CU

DPZ

CXS

TN

ADVUL

CQM

MGP

MGG

CRA1

CY1B

CS

Auto switch

D

Auto switch

AC,AD

HR

RB

RBQ

Twin Rod Cylinder

Double Acting, Single Rod / Double Rod

Series CXS, CXSW

CXSM □-□ Φ 10,15
CXSL □-□ Φ 10,15

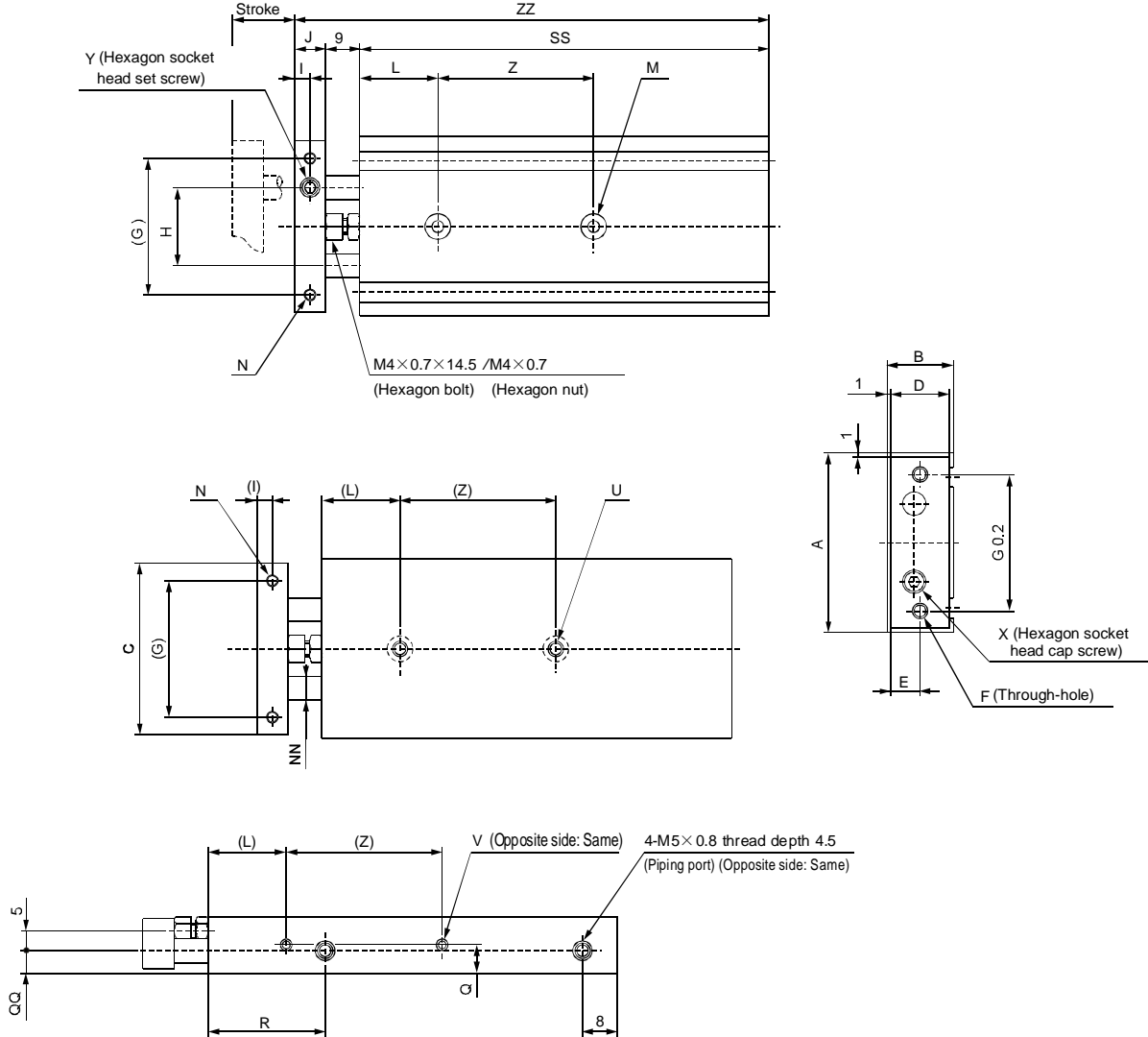

Note): Slide bearing (M) and ball bushing bearing (L) are same dimensions.

(mm)

Model	A	B	C	D	E	F	G	H	I	J	L	M	N	NN	P	Q	QQ	R	U	V	X	Y
CXS □10	46	17	44	15	7.5	2-M4×0.7	35	20	4	8	20	2-Φ3.4 through 2-Φ6.5 counterbore depth 3.3	2-M3×0.5 thread depth 5	Φ6	33.6	8.5	7	30	2-M4×0.7 thread depth 7	4-M3×0.5 thread depth 4.5	M3×0.5 × 10 /	M5×0.8 × 5 /
CXS □15	58	20	56	18	9	2-M5×0.8	45	25	5	10	30	2-Φ4.3 through 2-Φ8 counterbore depth 4.4	2-M4×0.7 thread depth 6	Φ8	48	10	10	38.5	2-M5×0.8 thread depth 8	4-M4×0.7 thread depth 5	M5×0.8 × 10 /	M6×1.0 × 5 s /

◆ **Dimensions by Stroke**

(mm)

Model	SS										Z					ZZ																			
	10	15	20	25	30	35	40	45	50	60	70	75	80	90	100	10,15	30, 35,	60,70,	80	90,100	10	15	20	25	30	35	40	45	50	60	70	75	80	90	100
CXS □10	65	70	75	80	85	90	95	100	105	115	125	130	-	-	-	30	40	50	-	-	82	87	92	97	102	107	112	117	122	132	142	147	-	-	
CXS □15	70	75	80	85	90	95	100	105	110	120	130	135	140	150	160	25	35	45	45	55	89	94	99	104	109	114	119	124	129	139	149	154	159	169	179

Twin Rod Cylinder

Double Acting, Single Rod / Double Rod

Series CXS, CXSW

ANSSION
PNEUMATIC & HYDRAULIC

CXSM □ - □ Φ 20,25,32

CXSL □ - □ Φ 20,25,32

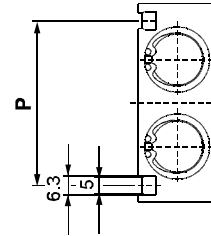
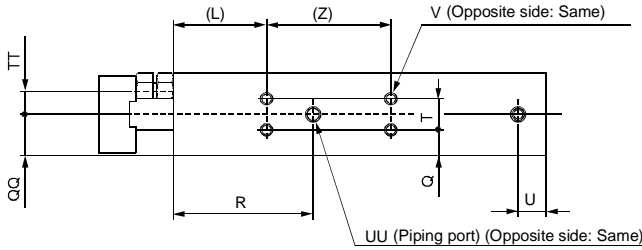
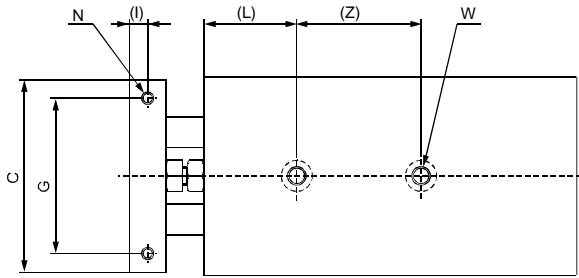
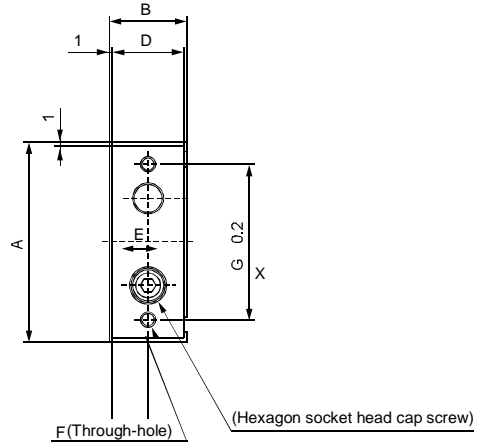
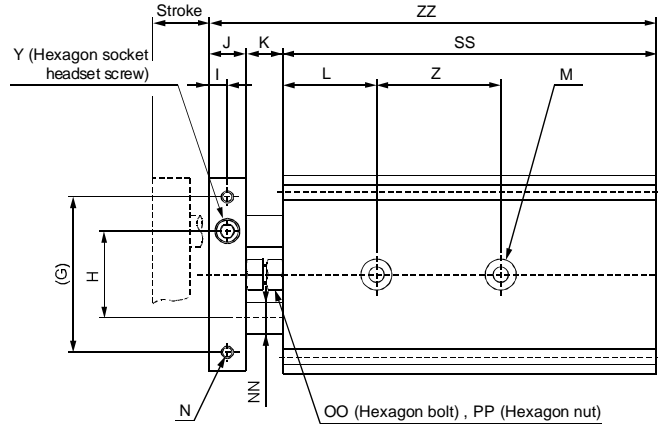

Note: Slide bearing (M) and ball bushing bearing (L) are same dimensions.

Model	A	B	C	D	E	F	G	H	I	J	K	L	M	N	NN	OO	P
CXS □ 20	64	25	62	23	11.5	2-M5×0.8 thread depth 5.3	50	28	6	12	12	30	2-Φ9.5 through counterbore depth 5.3	2-M4×0.7 thread depth 6	Φ10	M6×1.0×18.5	53
CXS □ 25	80	30	78	28	14	2-M6×1.0 thread depth 6.3	60	35	6	12	12	30	2-Φ11 through counterbore depth 6.3	2-M5×0.8 thread depth 7.5	Φ12	M6×1.0×18.5	64
CXS □ 32	98	38	96	36	18	2-M6×1.0 thread depth 6.3	75	44	8	16	14	30	2-Φ11 through counterbore depth 6.3	2-M5×0.8 thread depth 8	Φ16	M8×1.25×23	76

Model	PP	Q	QQ	R	T	TT	U	UU	V	W	X	Y
CXS □ 20	M6×1.0	7.75	12.5	45	9.5	6.5	8	4-M5×0.8 thread depth 4.5	8-M4×0.7 thread depth 5.5	2-M6×1.0 thread depth 10	M6×1.0×12	M8×1.25×6
CXS □ 25	M6×1.0	8.5	15	46	13	9	9	4-Rc 1/8 thread depth 6.5	8-M5×0.8 thread depth 7.5	2-M8×1.25 thread depth 12	M6×1.0×14	M8×1.25×6
CXS □ 32	M8×1.25	9	19	56	20	11.5	10	4-Rc 1/8 thread depth 6.5	8-M5×0.8 thread depth 7.5	2-M8×1.25 thread depth 12	M8×1.25×16	M10×1.5×8

◆ Dimensions by Stroke

Symbol Stroke Model	SS										Z			ZZ																			
	10	16	20	25	30	35	40	45	50	60	70	75	80	90	100	10, 15, 20, 25	30, 35, 40, 45, 50	60, 70, 75, 80, 90, 100	10	15	20	25	30	35	40	45	50	60	70	75	80	90	100
CXS □ 20	80	85	90	95	100	105	110	115	120	130	140	145	150	160	170	30	40	60	104	109	114	119	124	129	134	139	144	154	164	169	174	184	194
CXS □ 25	82	87	92	97	102	107	112	117	122	132	142	147	152	162	172	30	40	60	106	111	116	121	126	131	136	141	146	156	166	171	176	186	196
CXS □ 32	92	97	102	107	112	117	122	127	132	142	152	157	162	172	182	40	50	70	122	127	132	137	142	147	152	157	162	172	182	187	192	202	212

I

CJP

CJ1

DNC

DNCB

DNG

C95

SI

CS1

MB

SU

SC

DSNU

C85

CJ2

CM2

MA

MAL

ADVU

CQ2

CQS

SDA

CU

DPZ

CXS

TN

ADVUL

CQM

MGP

MGG

CRA1

CY1B

CS

D

AC,AD

HR

RB

RBQ

Twin Rod Cylinder

Double Acting, Single Rod / Double Rod

Series CXS, CXSW

◆ Dimensions

CXSW□-□ Φ6
CXSWL□-□ Φ6

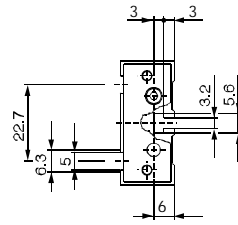
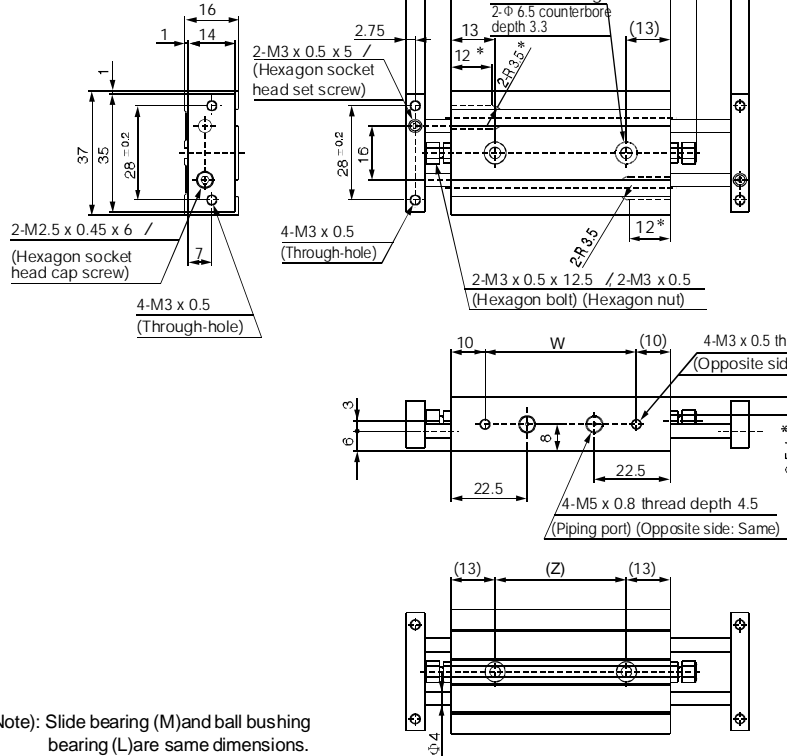

Model	S	SS	ZZ	Z	W
CXSW□6-10	10	66	103	40	46
CXSW□6-20	20	76	123	50	56
CXSW□6-30	30	86	143	60	66
CXSW□6-40	40	96	163	70	76
CXSW□6-50	50	106	183	80	86

Note): Slide bearing (M) and ball bushing bearing (L) are same dimensions.

* Only the CXSW□6-10 and the CXSW□6-20 have a groove cut out for installing auto switches. (The dimensions are marked “*”)

CXSWM□-□ Φ10
CXSWL□-□ Φ10

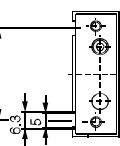
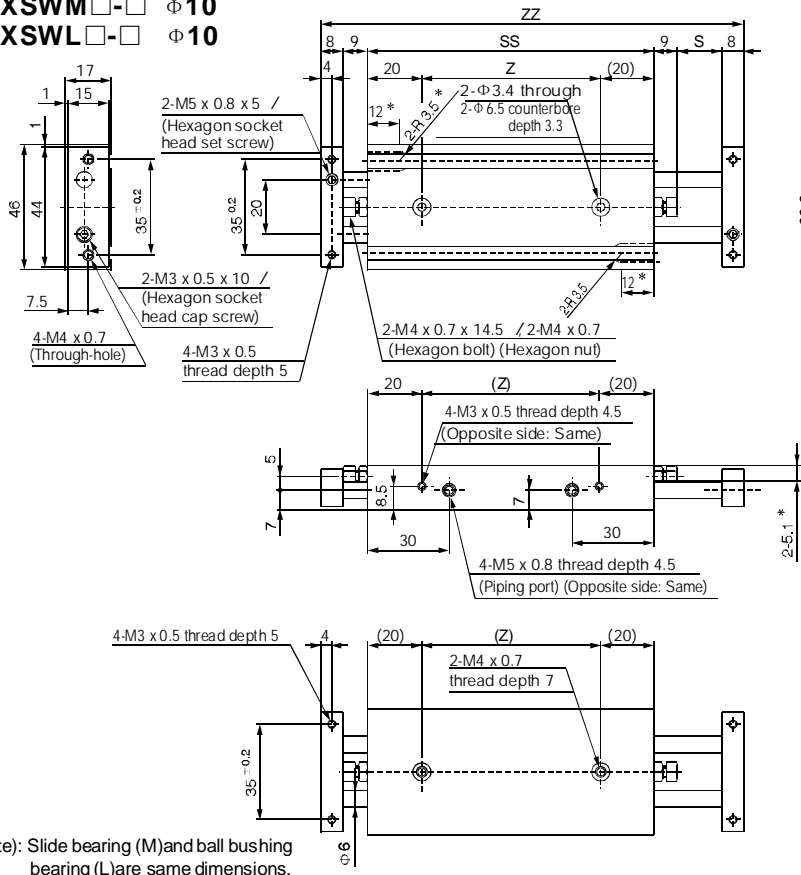

	Model	S	SS	ZZ	Z
Standard stroke	CXSW□10-10	10	92	136	52
	CXSW□10-20	20	102	156	62
	CXSW□10-30	30	112	176	72
	CXSW□10-40	40	122	196	82
	CXSW□10-50	50	132	216	92
Long stroke (-XB11)	CXSW□10-75	75	157	266	117
	CXSW□10-100	100	182	316	142
	CXSW□10-125	125	207	366	167
	CXSW□10-150	150	232	416	192

Note): Slide bearing (M) and ball bushing bearing (L) are same dimensions.

* Only the CXSW□10-10 and the CXSW□10-20 have a groove cut out for installing auto switches. (The dimensions are marked “*”)

Twin Rod Cylinder

Double Acting, Single Rod / Double Rod

Series CXS, CXSW



CXSW□-□ Φ15
CXSWL□-□ Φ15

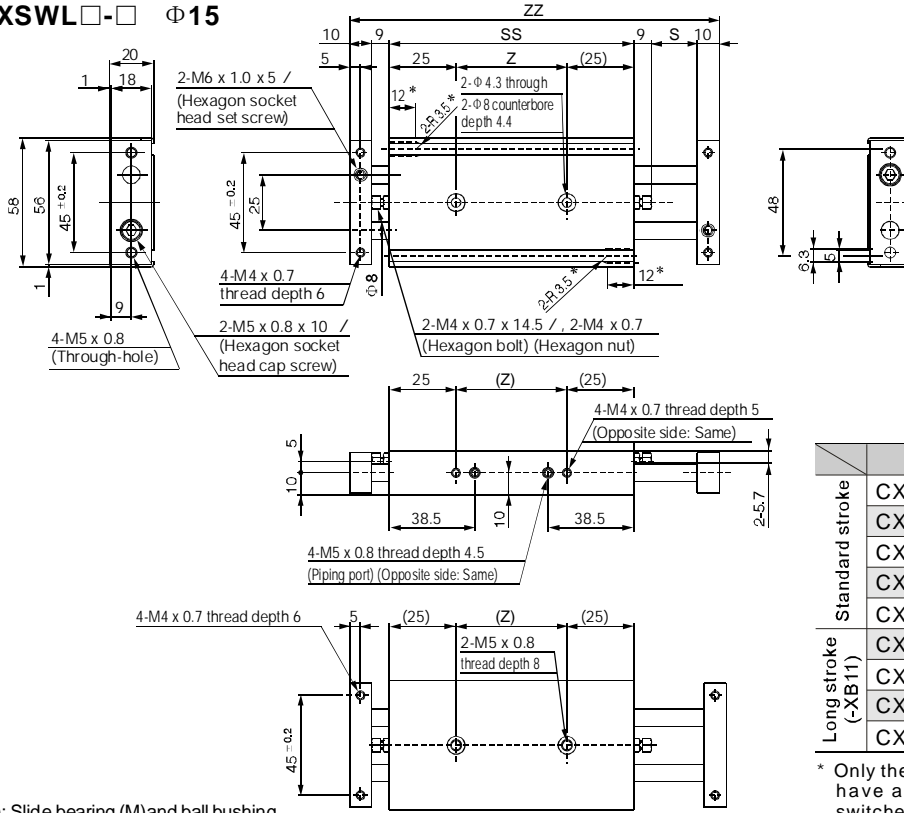

Note): Slide bearing (M) and ball bushing bearing (L) are same dimensions.

		(mm)				
		Model	S	SS	ZZ	Z
Standard stroke	CXSW□15-10	10	105	153	55	
	CXSW□15-20	20	115	173	65	
	CXSW□15-30	30	125	193	75	
	CXSW□15-40	40	135	213	85	
	CXSW□15-50	50	145	233	95	
Long stroke (-XB11)	CXSW□15-75	75	170	283	120	
	CXSW□15-100	100	195	333	145	
	CXSW□15-125	125	220	383	170	
	CXSW□15-150	150	245	433	195	

* Only the CXSW□15-10 and the CXSW□15-20 have a groove cut out for installing auto switches. (The dimensions are marked “*”)

CXSWM□-□ Φ20
CXSWL□-□ Φ20

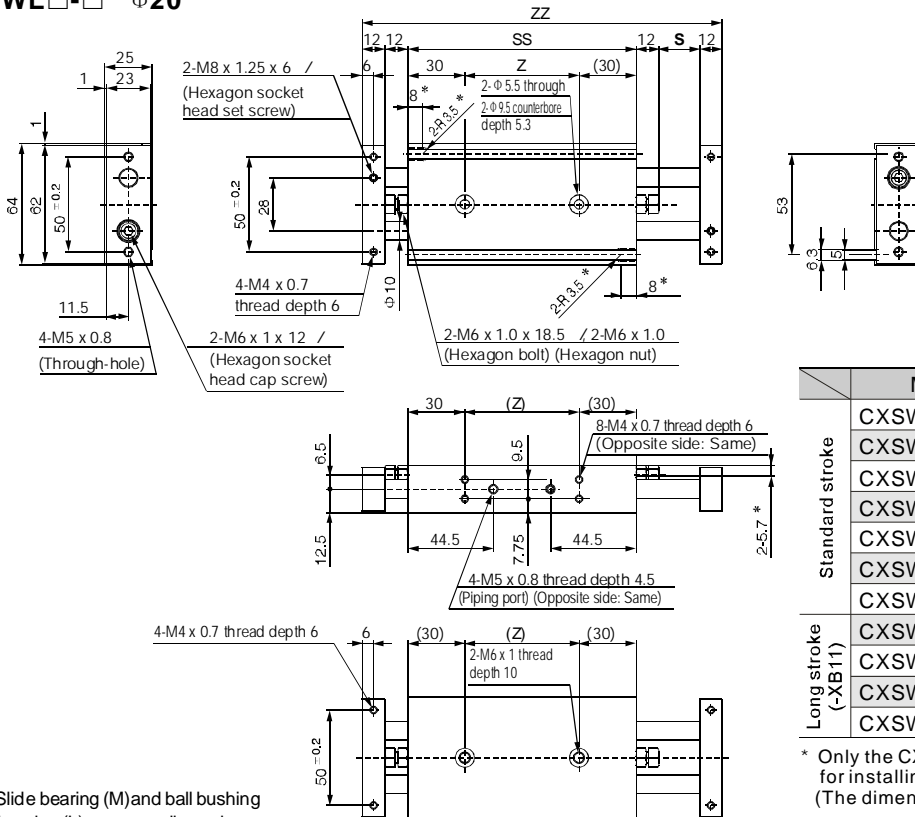

Note): Slide bearing (M) and ball bushing bearing (L) are same dimensions.

		(mm)				
		Model	S	SS	ZZ	Z
Standard stroke	CXSW□20-10	10	120	178	60	
	CXSW□20-20	20	130	198	70	
	CXSW□20-30	30	140	218	80	
	CXSW□20-40	40	150	238	90	
	CXSW□20-50	50	160	258	100	
	CXSW□20-75	75	185	308	125	
	CXSW□20-100	100	210	358	150	
	CXSW□20-125	125	235	408	175	
	CXSW□20-150	150	260	458	200	
	CXSW□20-175	175	285	508	225	
Long stroke (-XB11)	CXSW□20-200	200	310	558	250	

* Only the CXSW□20-10 has a groove cut out for installing auto switches. (The dimensions are marked “*”)

I
CJP
CJ1
DNC
DNCB
DNG
C95
SI
CS1
MB
SU
SC
DSNU
C85
CJ2
CM2
MA
MAL
ADVU
CQ2
CQS
SDA
CU
DPZ
CXS
TN
ADVUL
CQM
MGP
MGG
CRA1
CY1B
CS Auto switch
D Auto switch
AC,AD
HR
RB
RBQ

Twin Rod Cylinder

Double Acting, Single Rod / Double Rod

Series CXS, CXSW

CXSW □ - □ $\Phi 25$
CXSWL □ - □ $\Phi 25$

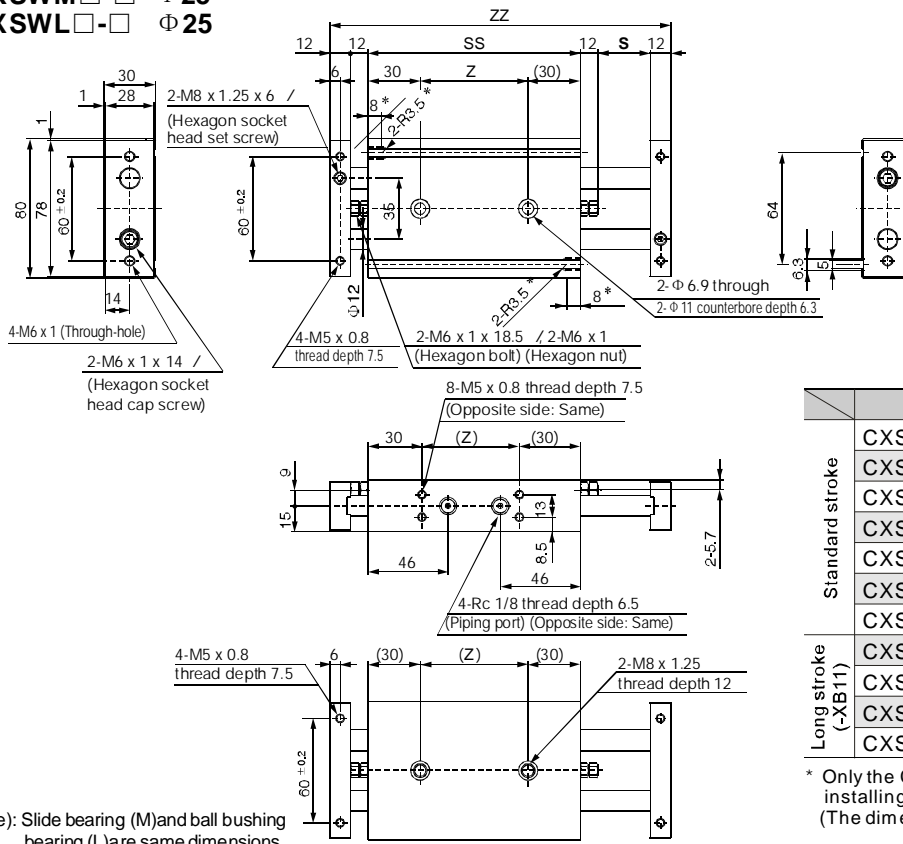

(mm)

	Model	S	SS	ZZ	Z
Standard stroke	CXSW □ 25-10	10	122	62	180
	CXSW □ 25-20	20	132	72	200
	CXSW □ 25-30	30	142	82	220
	CXSW □ 25-40	40	152	92	240
	CXSW □ 25-50	50	162	102	260
	CXSW □ 25-75	75	187	127	310
Long stroke (-XB11)	CXSW □ 25-125	125	237	177	410
	CXSW □ 25-150	150	262	202	460
	CXSW □ 25-175	175	287	227	510
	CXSW □ 25-200	200	312	252	560

* Only the CXSW □ 25-10 has a groove cut out for installing auto switches.
(The dimensions are marked “**”)

CXSW □ - □ $\Phi 32$
CXSWL □ - □ $\Phi 32$

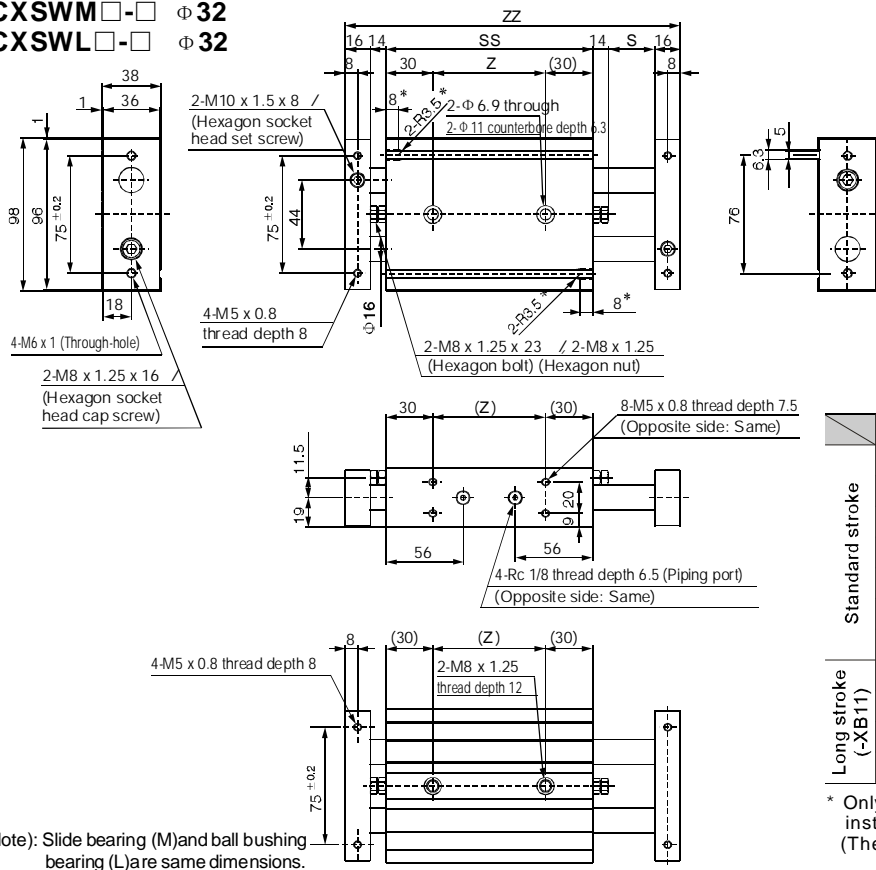

(mm)

	Model	S	SS	ZZ	Z
Standard stroke	CXSW □ 32-10	10	143	213	83
	CXSW □ 32-20	20	153	233	93
	CXSW □ 32-30	30	163	253	103
	CXSW □ 32-40	40	173	273	113
	CXSW □ 32-50	50	183	293	123
	CXSW □ 32-75	75	208	343	148
Long stroke (-XB11)	CXSW □ 32-100	100	233	393	173
	CXSW □ 32-125	125	258	443	198
	CXSW □ 32-150	150	283	493	223
	CXSW □ 32-175	175	308	543	248
CXSW □ 32-200	200	333	593	273	

* Only the CXSW □ 32-10 has a groove cut out for installing auto switches.
(The dimensions are marked “**”)